

## 145-12-SD

150 Watt, non isolated, single output buck converter  
All parameters defined on  $T_a=25^{\circ}\text{C}$ ,  $I_{oNom} = 12,0\text{ ADC}$  and  $U_{iNom} = 80\text{VDC}$

### ABSOLUTE MAXIMUM RATINGS

parameter	unit	typ
Input peak voltage	VDC	125.00
Feedback protection against overvoltage on the output	VDC	16
Worst case output voltage in fault mode	VDC	23
Output overvoltage protection	VDC	15.5

### THERMAL CHARACTERISTICS

parameter	min to max	typ
Ambient temperature range	$-40^{\circ}\text{C} / +85^{\circ}\text{C}$	
Max. case temperature for thermal shut down [ $^{\circ}\text{C}$ ]		$+90^{\circ}\text{C}$
Storage temperature [device not in operation]	$-10^{\circ}\text{C} / +65^{\circ}\text{C}$	
Relative maximum humidity under storage		75% RH
Storage under worst conditions [in days]		25

### COMMUNICATION INTERFACE

parameter	unit	fulfilled	min to max
Option shut down [left open for operation]		✓	

### SPECIALS

parameter	unit	conditions	typ
Switching frequency	kHz		150
Efficiency at medium loads	%	$0.5I_{oNom}$	92.50
Efficiency at full loads	%	$I_{oNom}$	90.60
MTTF	h	SN29500 @ $70^{\circ}$	1 100 000

### COMPLIANCE

parameter	fulfilled	notes
61000-6-2 [EMC-Immunity standard for industrial environment]	✓	
61000-4-3 [immunity High frequency electromagnetic fields]	✓	
61000-4-4 [immunity against burst - electrical fast transients]	✓	
61000-4-5 [immunity against surge - high energy surges]	✓	
61000-4-6 [immunity against induced, conducted disturbances]	✓	
61000-6-4 [EMC - Emission standard for industrial environment]	✓	
55022<A	✓	

All technical and general information is provided in all conscience. However, completeness and accuracy cannot be guaranteed. Demke recommends to fully test the product in its determined application. Due to permanent improvements to our products, we reserve the right to change specifications at any time and without prior notification and without obligation to update products already supplied. This is a component for professional equipment manufacturers. Read the safety and installation instruction for proper use. Safety aspect and EMC-aspect must be considered in the end application.

## 145-12-SD

150 Watt, non isolated, single output buck converter

### INPUT

parameter	unit	conditions	min	typ	max
Input voltage range	VDC	IoNom	16	80	100
No load input current	mA	UiNom		10	
Max. input current	A	UiNom		10	
Input start up voltage	VDC	UiNom		14.2	
Undervoltage lockout	VDC	UiNom		12.6	
Input quiescent current in shutdown mode	mA	UiNom		1.50	
Input current overshoot during soft start ramp up	%	IoNom		65	
Generated AC-ripple on the supply (BW=20MHz)	mVp-p	UiNom/IoNom		85	
Generated HF-noise on the supply (BW=20MHz)	mVp-p	UiNom/IoNom		35	
Typical input noise slew rate (BW=500MHz)	mVp-p	UiNom/IoNom		40	

### OUTPUT

parameter	unit	conditions	min	typ	max
Output voltage	VDC	IoNom		12.0	
Minimum required load to obtain the specified output voltage	%	UiNom		0	
Generated AC-ripple on the output (BW=20MHz)	mVp-p	UiNom/IoNom		60	
Generated HF-noise on the output (BW=20MHz)	mVp-p	UiNom/IoNom		50	
Typical output noise slew rate (BW=500MHz)	mVp-p	UiNom/IoNom		150	
Output voltage accuracy	%	IoNom		+/-2,00%	
Output voltage overshoot at initial switch-on	%	IoNom		overdamped	
Rated output power	W			150	

### CONTROL

parameter	unit	conditions	min	typ	max
Static line regulation	%	IoNom/UiMin...UiMax		0.05	
Static load regulation	%	IoMin...IoMax/UiNom		0.5	
Dynamic load change adjusting time	ms	LoadChange 10...90%		0.60	
Dynamic load change deviation to nominal output voltage	V	LoadChange 10...90%		0.80	
Maximum admissible capacitive load	uF	IoNom		infinite	
Initial switch on time	ms	IoNom		30	
Softstart ramp up time	ms	IoNom		15	

All technical and general information is provided in all conscience. However, completeness and accuracy cannot be guaranteed. Demke recommends to fully test the product in its determined application. Due to permanent improvements to our products, we reserve the right to change specifications at any time and without prior notification and without obligation to update products already supplied. This is a component for professional equipment manufacturers. Read the safety and installation instruction for proper use. Safety aspect and EMC-aspect must be considered in the end application.

## 145-12-SD

150 Watt, non isolated, single output buck converter

### MECHANICAL parameter

parameter	unit	
Overall dimensions	mm	77x52x19
Weight	g	165

Pin No.	Function	Electrical Determination
1	SD	Shut down
2	Vi+	Input voltage positive
3	Vi-	Input voltage negative
4	Vo-	Output voltage negative
5	Vo+	Output voltage positive

### Mechanical dimensions and Pin configuration

All dimensions in mm

Connector type: CCA 2,5/5-G-5,08 P26THR

Case: FMC 77x52x19

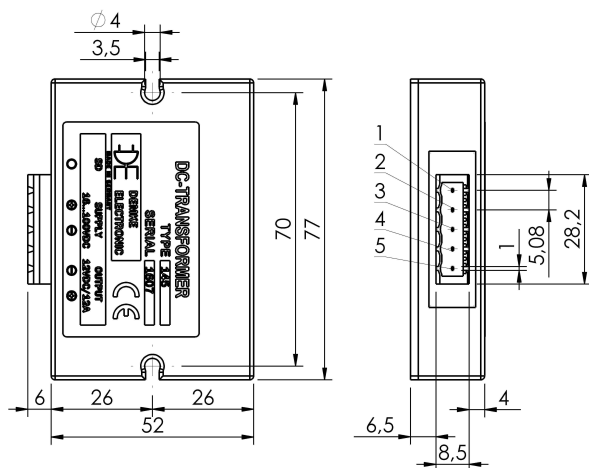

All technical and general information is provided in all conscience. However, completeness and accuracy cannot be guaranteed. Demke recommends to fully test the product in its determined application. Due to permanent improvements to our products, we reserve the right to change specifications at any time and without prior notification and without obligation to update products already supplied. This is a component for professional equipment manufacturers. Read the safety and installation instruction for proper use. Safety aspect and EMC-aspect must be considered in the end application.