

## 337-13.8-SD

80 Watt, isolated, single output buck converter with internal decoupling diode

All parameters defined on  $T_a=25^{\circ}\text{C}$ ,  $I_{oNom} = 6,0\text{ ADC}$  and  $U_{iNom} = 48\text{VDC}$

### ABSOLUTE MAXIMUM RATINGS

parameter	unit	typ
Input peak voltage	VDC	100.00

### THERMAL CHARACTERISTICS

parameter	min to max	typ
Ambient temperature range	$-40^{\circ}\text{C} / +85^{\circ}\text{C}$	
Max. case temperature for thermal shut down [ $^{\circ}\text{C}$ ]		$+90^{\circ}\text{C}$
Storage temperature [device not in operation]	$-10^{\circ}\text{C} / +85^{\circ}\text{C}$	
Relative maximum humidity under storage		75% RH
Storage under worst conditions [in days]		25

### COMMUNICATION INTERFACE

parameter	unit	fulfilled	conditions	min to max
Option shut down [left open for operation]		✓		
Shutdown voltage for transformer	VDC		$I_{oNom}$	-0,2 to 2,8

### SPECIALS

parameter	unit	fulfilled	conditions	typ
Switching frequency	kHz			120
Efficiency at light loads	%		$0.25I_{oNom}$	92.00
Efficiency at medium loads	%		$0.5I_{oNom}$	92.00
Efficiency at full loads	%		$I_{oNom}$	92.00
MTTF	h		SN29500 @ $70^{\circ}$	1 600 000
For active loads or parallel connection		✓		
Drives high capacitive loads		✓		
CC/CV battery load characteristic		✓		
Coupling capacitance input to output	nF			transformer winding only
Insulation strength primary to secondary	VDC			2100
Insulation strength primary to case	VDC			2100

### COMPLIANCE

parameter	fulfilled	notes
61000-6-2 [EMC-Immunity standard for industrial environment]	✓	
61000-4-2 [immunity against ESD-electrostatic discharge]	✓	
61000-4-3 [immunity High frequency electromagnetic fields]	✓	
61000-4-4 [immunity against burst – electrical fast transients]	✓	
61000-4-5 [immunity against surge - high energy surges]	✓	
61000-4-6 [immunity against induced, conducted disturbances]	✓	
61000-6-4 [EMC – Emission standard for industrial environment]	✓	

All technical and general information is provided in all conscience. However, completeness and accuracy cannot be guaranteed. Demke recommends to fully test the product in its determined application. Due to permanent improvements to our products, we reserve the right to change specifications at any time and without prior notification and without obligation to update products already supplied. This is a component for professional equipment manufacturers. Read the safety and installation instruction for proper use. Safety aspect and EMC-aspect must be considered in the end application.

## 337-13.8-SD

80 Watt, isolated, single output buck converter with internal decoupling diode

55022<A	✓	
50121	✓	ready for
50155	✓	ready for

All technical and general information is provided in all conscience. However, completeness and accuracy cannot be guaranteed. Demke recommends to fully test the product in its determined application. Due to permanent improvements to our products, we reserve the right to change specifications at any time and without prior notification and without obligation to update products already supplied. This is a component for professional equipment manufacturers. Read the safety and installation instruction for proper use. Safety aspect and EMC-aspect must be considered in the end application.

## 337-13.8-SD

80 Watt, isolated, single output buck converter with internal decoupling diode

### INPUT

parameter	unit	conditions	min	typ	max
Input voltage range	VDC	IoNom	22	48	80
Max. input current	A	UiNom		4	
Input start up voltage	VDC	UiNom		20.0	
Undervoltage lockout	VDC	UiNom		18.0	

### OUTPUT

parameter	unit	conditions	min	typ	max
Output voltage	VDC	IoNom		13.8	
Minimum required load to obtain the specified output voltage	%	UiNom		2	
Output voltage accuracy	%	IoNom		+/-2,00%	
Output voltage overshoot at initial switch-on	%	IoNom		overdamped	
Rated output power	W			80	

### CONTROL

parameter	unit	conditions	min	typ	max
Maximum admissible capacitive load	uF	IoNom		infinite	
Initial switch on time	ms	IoNom		50	
Softstart ramp up time	ms	IoNom		15	
Restart time after undervoltage lockout	ms	IoNom		50	

All technical and general information is provided in all conscience. However, completeness and accuracy cannot be guaranteed. Demke recommends to fully test the product in its determined application. Due to permanent improvements to our products, we reserve the right to change specifications at any time and without prior notification and without obligation to update products already supplied. This is a component for professional equipment manufacturers. Read the safety and installation instruction for proper use. Safety aspect and EMC-aspect must be considered in the end application.

## 337-13.8-SD

80 Watt, isolated, single output buck converter with internal decoupling diode

### MECHANICAL parameter

parameter	unit	
Overall dimensions	mm	52x77x19
Weight	g	170

Pin No.	Function	Electrical Determination
1	SD	Shut down
2	Vi+	Input voltage positive
3	Vi-	Input voltage negative
4	NC	Not connected
5	NC	Not connected
6	Vo-	Output voltage negative
7	Vo+	Output voltage positive

### Mechanical dimensions and Pin configuration

All dimensions in mm

Connector type: MC 1,5/7-G-3,81 P26THR

Case: FMC 77x52x19

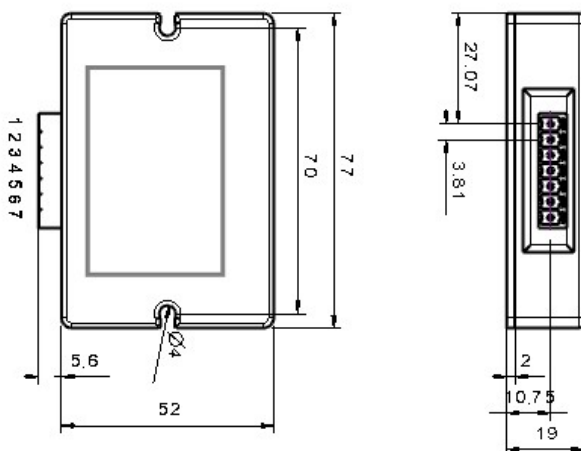

All technical and general information is provided in all conscience. However, completeness and accuracy cannot be guaranteed. Demke recommends to fully test the product in its determined application. Due to permanent improvements to our products, we reserve the right to change specifications at any time and without prior notification and without obligation to update products already supplied. This is a component for professional equipment manufacturers. Read the safety and installation instruction for proper use. Safety aspect and EMC-aspect must be considered in the end application.