

364W2-15015-SDB1

120 Watt, isolated, bipolar output buck converter

All parameters defined on $T_a=25^{\circ}\text{C}$, $I_{oNom} = 8,0\text{ ADC}$ and $U_{iNom} = 80\text{VDC}$

ABSOLUTE MAXIMUM RATINGS

parameter	unit	typ
Input peak voltage	VDC	170.00
Feedback protection against overvoltage on the output	VDC	18
Worst case output voltage in fault mode	VDC	24

THERMAL CHARACTERISTICS

parameter	min to max	typ
Ambient temperature range	$-40^{\circ}\text{C} / +85^{\circ}\text{C}$	
Max. case temperature for thermal shut down [$^{\circ}\text{C}$]		$+90^{\circ}\text{C}$
Storage temperature [device not in operation]	$-10^{\circ}\text{C} / +65^{\circ}\text{C}$	
Relative maximum humidity under storage		75% RH
Storage under worst conditions [in days]		25

COMMUNICATION INTERFACE

parameter	unit	fulfilled	conditions	min to max
Option shut down [left open for operation]		✓		
Shutdown voltage for transformer	VDC		I_{oNom}	-0,2 to 2,8
Option Switch high [left open for normal operation]		✓		
Switch high control voltage for transformer	VDC		I_{oNom}	-0,2 to 0,2
Output voltage in switch high mode	VDC		I_{oNom}	15.5

SPECIALS

parameter	unit	fulfilled	conditions	typ
Switching frequency	kHz			120
Efficiency at light loads	%		$0.25I_{oNom}$	92.00
Efficiency at medium loads	%		$0.5I_{oNom}$	89.00
Efficiency at full loads	%		I_{oNom}	88.30
MTTF	h		SN29500 @ 70°	1 600 000
For active loads or parallel connection		✓		
Drives high capacitive loads		✓		
CC/CV battery load characteristic		✓		
Coupling capacitance input to output	nF			transformer winding only
Insulation strength primary to secondary	VDC			2100
Insulation strength primary to case	VDC			2100

COMPLIANCE

parameter	fulfilled	notes
61000-6-2 [EMC-Immunity standard for industrial environment]	✓	
61000-4-2 [immunity against ESD-electrostatic discharge]	✓	

All technical and general information is provided in all conscience. However, completeness and accuracy cannot be guaranteed. Demke recommends to fully test the product in its determined application. Due to permanent improvements to our products, we reserve the right to change specifications at any time and without prior notification and without obligation to update products already supplied. This is a component for professional equipment manufacturers. Read the safety and installation instruction for proper use. Safety aspect and EMC-aspect must be considered in the end application.

364W2-15015-SDB1

120 Watt, isolated, bipolar output buck converter

61000-4-3 (immunity High frequency electromagnetic fields)	✓
61000-4-4 (immunity against burst - electrical fast transients)	✓
61000-4-5 (immunity against surge - high energy surges)	✓
61000-4-6 (immunity against induced, conducted disturbances)	✓
61000-6-4 (EMC - Emission standard for industrial environment)	✓
55022<A	✓

All technical and general information is provided in all conscience. However, completeness and accuracy cannot be guaranteed. Demke recommends to fully test the product in its determined application. Due to permanent improvements to our products, we reserve the right to change specifications at any time and without prior notification and without obligation to update products already supplied. This is a component for professional equipment manufacturers. Read the safety and installation instruction for proper use. Safety aspect and EMC-aspect must be considered in the end application.

364W2-15015-SDB1

120 Watt, isolated, bipolar output buck converter

INPUT

parameter	unit	conditions	min	typ	max
Input voltage range	VDC	IoNom	16	80	160
No load input current	mA	UiNom		24	
Max. input current	A	UiNom		8	
Input start up voltage	VDC	UiNom		16.6	
Undervoltage lockout	VDC	UiNom		15.4	
Input quiescent current in shutdown mode	mA	UiNom		6.00	
Generated AC-ripple on the supply [BW=20MHz]	mVp-p	UiNom/IoNom		520	
Generated HF-noise on the supply [BW=20MHz]	mVp-p	UiNom/IoNom		60	
Typical input noise slew rate [BW=500MHz]	mVp-p	UiNom/IoNom		50	
Reflected input ripple current	mA _{p-p}	UiNom/IoNom		400	

OUTPUT

parameter	unit	conditions	min	typ	max
Bipolar output voltage	VDC	IoNom		+/- 15	
No Load output voltage increase	%	UiNom		4	
Minimum required load to obtain the specified output voltage	%	UiNom		5	
Generated AC-ripple on the output [BW=20MHz]	mVp-p	UiNom/IoNom		10	
Generated HF-noise on the output [BW=20MHz]	mVp-p	UiNom/IoNom		40	
Typical output noise slew rate [BW=500MHz]	mVp-p	UiNom/IoNom		50	
Output voltage accuracy	%	IoNom		+/-2,00%	
Output voltage overshoot at initial switch-on	%	IoNom		overdamped	
Rated output power	W			120	
Cross regulation + to - output or third output	%			3	

CONTROL

parameter	unit	conditions	min	typ	max
Static line regulation	%	IoNom/UiMin...UiMax		0.10	
Static load regulation	%	IoMin...IoMax/UiNom		8.0	
Dynamic load change adjusting time	ms	LoadChange 10...90%		0.30	
Dynamic load change deviation to nominal output voltage	V	LoadChange 10...90%		2.50	
Maximum admissible capacitive load	uF	IoNom		infinite	
Initial switch on time	ms	IoNom		15	
Softstart ramp up time	ms	IoNom		10	

All technical and general information is provided in all conscience. However, completeness and accuracy cannot be guaranteed. Demke recommends to fully test the product in its determined application. Due to permanent improvements to our products, we reserve the right to change specifications at any time and without prior notification and without obligation to update products already supplied. This is a component for professional equipment manufacturers. Read the safety and installation instruction for proper use. Safety aspect and EMC-aspect must be considered in the end application.

364W2-15015-SDB1

120 Watt, isolated, bipolar output buck converter

MECHANICAL parameter

parameter	unit	
Overall dimensions	mm	90x90x25
Weight	g	380

Pin No.	Function	Electrical Determination
1	Vi+	Input voltage positive
2	Vi-	Input voltage negative
3	SD	Shut down
4	SH	Switch high
6	Vo-	Output voltage negative
7	GO	Output voltage common
8	Vo+	Output voltage positive

Mechanical dimensions and Pin configuration

All dimensions in mm

Connector type: CC 2,5/8-GF-5,08 P26THR

Case: FMC 90x90x26

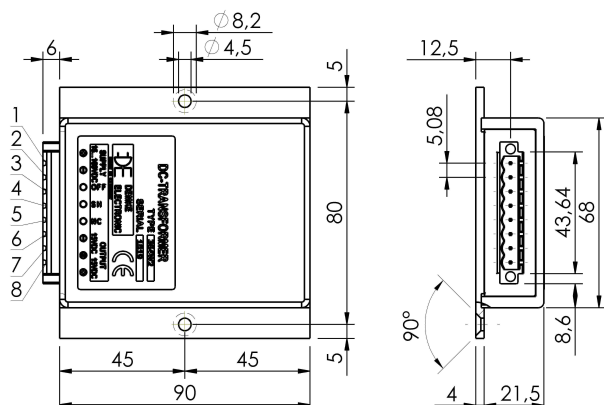

All technical and general information is provided in all conscience. However, completeness and accuracy cannot be guaranteed. Demke recommends to fully test the product in its determined application. Due to permanent improvements to our products, we reserve the right to change specifications at any time and without prior notification and without obligation to update products already supplied. This is a component for professional equipment manufacturers. Read the safety and installation instruction for proper use. Safety aspect and EMC-aspect must be considered in the end application.