

Master-7xx.xx

400 Watt, isolated, single output buck-boost converter

All parameters defined on $T_a=25^{\circ}\text{C}$, $I_{oNom} = 16,5 \text{ ADC}$ and $U_{iNom} = 24\text{VDC}$

ABSOLUTE MAXIMUM RATINGS

parameter	unit	typ
Input peak voltage	VDC	150.00

THERMAL CHARACTERISTICS

parameter	min to max	typ
Ambient temperature range	$-40^{\circ}\text{C} / +85^{\circ}\text{C}$	
Max. case temperature for thermal shut down [$^{\circ}\text{C}$]		$+90^{\circ}\text{C}$
Storage temperature [device not in operation]	$-10^{\circ}\text{C} / +65^{\circ}\text{C}$	
Relative maximum humidity under storage		75% RH
Storage under worst conditions [in days]		25

COMMUNICATION INTERFACE

parameter	unit	fulfilled	conditions	min to max
Option shut down [left open for operation]		✓		
Shutdown voltage for transformer	VDC		I_{oNom}	-0,2 to 2,8

SPECIALS

parameter	unit	fulfilled	conditions	typ
Switching frequency	kHz			125
Efficiency at light loads	%		$0.25I_{oNom}$	96.00
Efficiency at medium loads	%		$0.5I_{oNom}$	95.00
Efficiency at full loads	%		I_{oNom}	94.00
MTTF	h		SN29500 @ 70°	123 456
For active loads or parallel connection		✓		
Drives high capacitive loads		✓		
CC/CV battery load characteristic		✓		
Coupling capacitance input to output	nF			transformer winding only
Insulation strength primary to secondary	VDC			2100
Insulation strength primary to case	VDC			2100

COMPLIANCE

parameter	fulfilled	notes
61000-6-2 [EMC-Immunity standard for industrial environment]	✓	
61000-4-2 [immunity against ESD-electrostatic discharge]	✓	
61000-4-3 [immunity High frequency electromagnetic fields]	✓	
61000-4-4 [immunity against burst – electrical fast transients]	✓	
61000-4-5 [immunity against surge - high energy surges]	✓	
61000-4-6 [immunity against induced, conducted disturbances]	✓	
61000-6-4 [EMC – Emission standard for industrial environment]	✓	

All technical and general information is provided in all conscience. However, completeness and accuracy cannot be guaranteed. Demke recommends to fully test the product in its determined application. Due to permanent improvements to our products, we reserve the right to change specifications at any time and without prior notification and without obligation to update products already supplied. This is a component for professional equipment manufacturers. Read the safety and installation instruction for proper use. Safety aspect and EMC-aspect must be considered in the end application.

Master-7xx.xx

400 Watt, isolated, single output buck-boost converter

55022<A	✓
50155	✓
Protection class	1

All technical and general information is provided in all conscience. However, completeness and accuracy cannot be guaranteed. Demke recommends to fully test the product in its determined application. Due to permanent improvements to our products, we reserve the right to change specifications at any time and without prior notification and without obligation to update products already supplied. This is a component for professional equipment manufacturers. Read the safety and installation instruction for proper use. Safety aspect and EMC-aspect must be considered in the end application.

Master-7xx.xx

400 Watt, isolated, single output buck-boost converter

INPUT

parameter	unit	conditions	min	typ	max
Input voltage range	VDC	IoNom	8	24	125
No load input current	mA	UiNom		30	
Max. input current	A	UiNom		30	
Input start up voltage	VDC	UiNom		7.5	
Undervoltage lockout	VDC	UiNom		5.5	
Input quiescent current in shutdown mode	mA	UiNom		0.50	

OUTPUT

parameter	unit	conditions	min	typ	max
Output voltage	VDC	IoNom		24.0	
No Load output voltage increase	%	UiNom		4	
Minimum required load to obtain the specified output voltage	%	UiNom		2	
Output voltage accuracy	%	IoNom		+/-2,00%	
Output voltage overshoot at initial switch-on	%	IoNom		overdamped	
Rated output power	W			400	

CONTROL

parameter	unit	conditions	min	typ	max
Static line regulation	%	IoNom/UiMin...UiMax		0.10	
Static load regulation	%	IoMin...IoMax/UiNom		0.3	
Initial switch on time	ms	IoNom		500	
Softstart ramp up time	ms	IoNom		30	
Restart time after undervoltage lockout	ms	IoNom		50	

All technical and general information is provided in all conscience. However, completeness and accuracy cannot be guaranteed. Demke recommends to fully test the product in its determined application. Due to permanent improvements to our products, we reserve the right to change specifications at any time and without prior notification and without obligation to update products already supplied. This is a component for professional equipment manufacturers. Read the safety and installation instruction for proper use. Safety aspect and EMC-aspect must be considered in the end application.

Master-7xx.xx

400 Watt, isolated, single output buck-boost converter

MECHANICAL parameter

parameter	unit	
Overall dimensions	mm	90x90x26
Weight	g	900

Pin No.	Function	Electrical Determination
1	Vi+	Input voltage positive
2	Vi-	Input voltage negative
3	SD	Shut down
4	Vo-	Output voltage negative
5	Vo+	Output voltage positive

Mechanical dimensions and Pin configuration

All dimensions in mm

Connector type:

Case: FMC 130x130x28

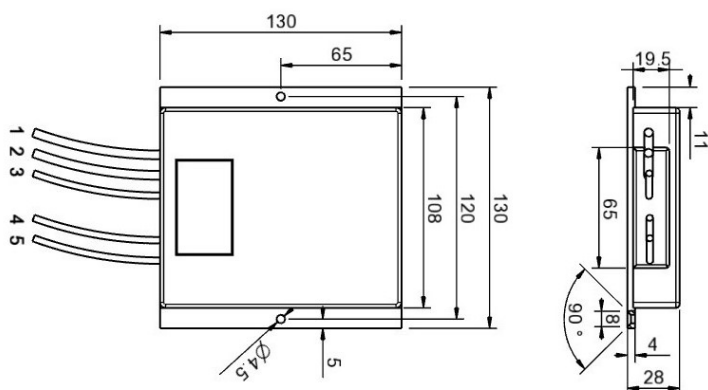

All technical and general information is provided in all conscience. However, completeness and accuracy cannot be guaranteed. Demke recommends to fully test the product in its determined application. Due to permanent improvements to our products, we reserve the right to change specifications at any time and without prior notification and without obligation to update products already supplied. This is a component for professional equipment manufacturers. Read the safety and installation instruction for proper use. Safety aspect and EMC-aspect must be considered in the end application.